



MOBILE UNITS

MOBILE FOAM CART

DESCRIPTION

The Buckeye Mobile Foam Cart is designed to hold 40 gallons (150 liters) of fire fighting foam concentrate, the Buckeye In-line 95 GPM Eductor, handline nozzle and one length of 1 1/2" rubber lined single jacket fire hose. The ease of handling and mobility of the foam cart makes this a very effective fire fighting unit for flammable liquid fires. To place the unit in operation, just connect a length of 1 1/2" fire hose from a suitable water supply to the in-line eductor inlet. The tank is manufactured from a high-density polyethylene which makes the unit suitable for use with all types of foam concentrates and environments.

FEATURES

- Nozzle features ball shut-off for better stream control and is designed to give a constant flow whether on straight stream or fog patterns.
- 3" x 16" semi-pneumatic tires for ease of handling on rough terrain.
- Fire hose has lightweight 1 1/2" NST couplings.
- Pick up tube for the in-line eductor is manufactured from Ultra-Violet resistant PVC.

OPTIONS

- Other nozzle selections.
- Cover, 18 oz. red vinyl coated nylon with "FOAM-UNIT" in 4" high white letters.

CAUTION

If using any of the AR-AFFF type foam concentrates in the unit, it is recommended that a thin layer of mineral oil be placed on the surface of the foam concentrate to minimize evaporation.

ORDERING INFORMATION

MODEL

BF-MFC 40

40 Gallon Mobile Foam Cart





MOBILE UNITS

40 - GALLON MOBILE FOAM CART

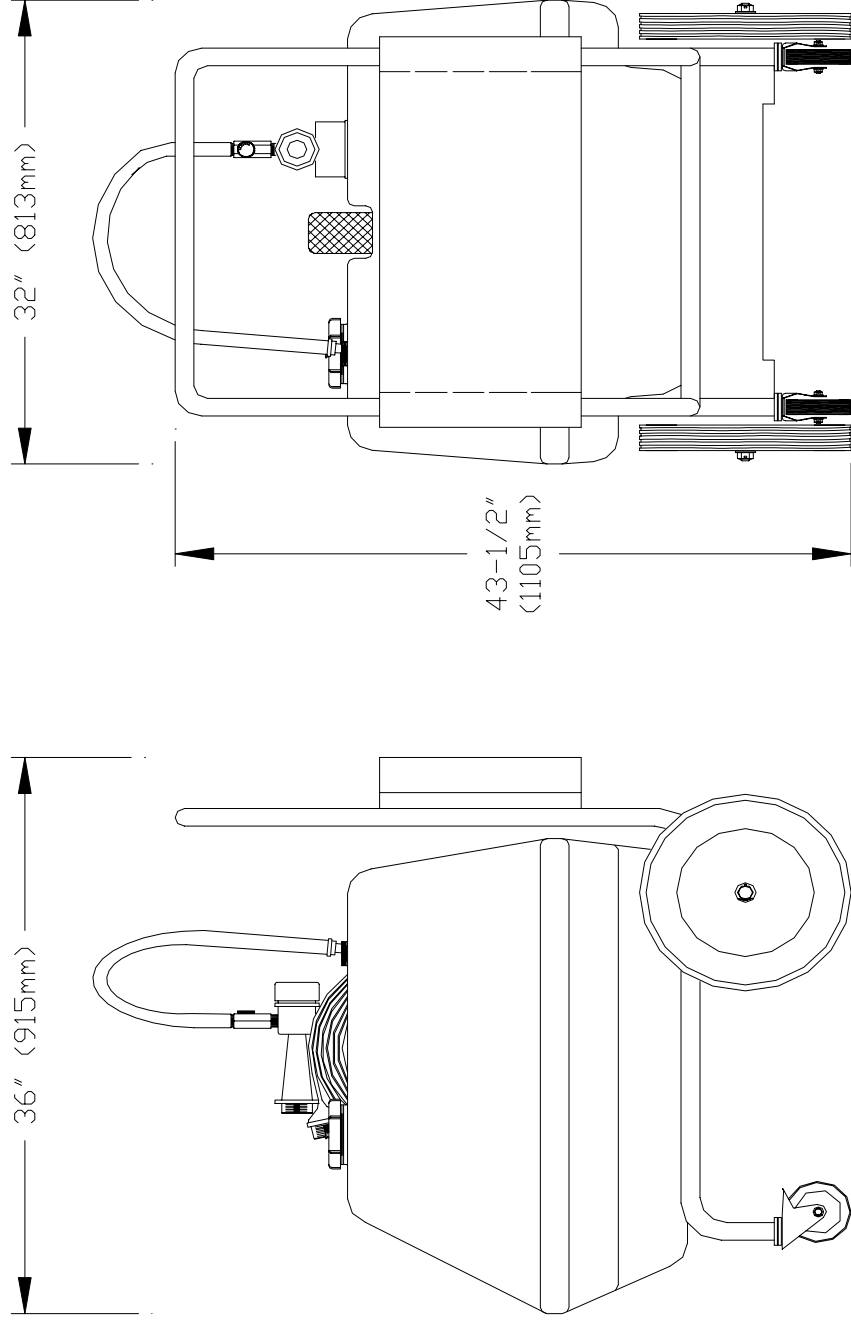



MOBILE UNITS

40 - GALLON MOBILE FOAM CART

